



51.2V 100AH Battery Pack

PRODUCT DESCRIPTION

The product belongs to one of the series of household energy storage products that are independently designed and developed by us. It is used for energy storage and energy supply to household, commercial, UPS and other electrical equipment.

This product enjoys many merits: long cycle life, high safety standard from software protection to strong housing, exquisite looks, and easy installation, etc. It is widely used in energy storage system with off-grid inverters, grid-connected inverters and hybrid inverters.

- ◆ Each battery pack is equipped with an intelligent battery management system to manage the modules efficiently.
- ◆ Compared with traditional modules, it can meet the capacity storage and greatly improve the cycle life.
- ◆ National high-tech enterprise, home intelligent energy management, safe, efficient and green energy



PRODUCT DETAILS

LONGER CYCLE LIFE

Offers up to 15 times longer cycle life and 5 times longer float/ calendar life than lead acid battery.

LOW SELF-DISCHARGE

Lower self-discharge compared with lead acid battery, longer storage time without recharging.

SUPERIOR SAFETY

Multi-protection methods built inside to protect the battery from overcharge, over discharge and short circuit situation.

HIGH EFFICIENT

Higher round-trip energy efficiency of the average (92%) than lead acid battery 80% (discharge from 100% to 0% and back to 100% charged).

LIGHTER WEIGHT

About 40% weight of a comparable lead acid battery. save up to 60% in weight.

QUICK CHARGE

Short charge time compared with lead acid battery.

Panel Indication

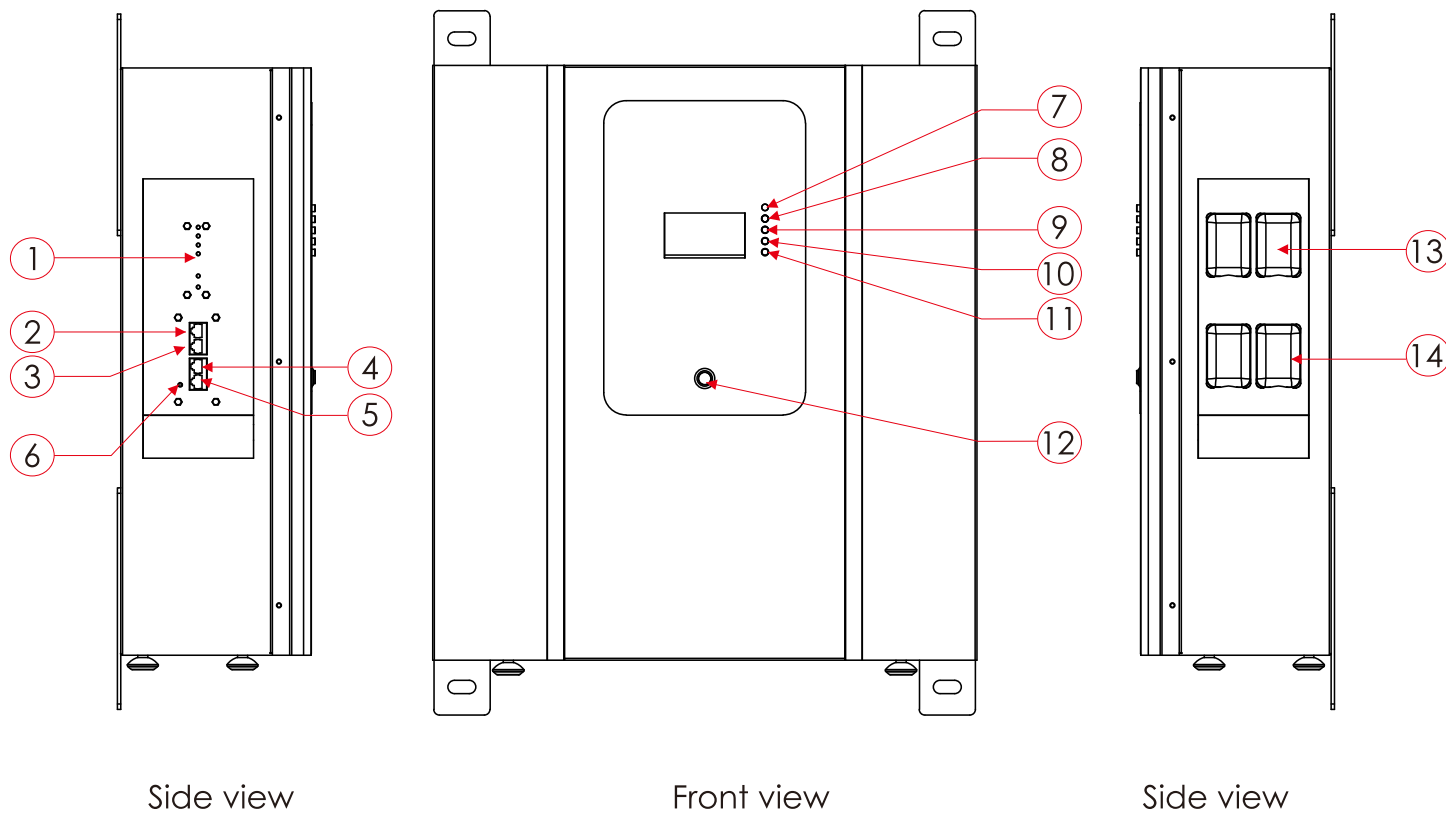

Item	Project	Explanation
1	LED	LED1, 2, 3, 4, 5, 6
2	CAN	Parallel port
3	CAN	Parallel port
4	RS485	Communication with upper computer
5	CAN	Communication with inverter
6	Reset switch	Reset switch
7	MENU	"MENU" key
8	ENTER	"ENTER" key
9	UP	"UP" key
10	DOWN	"DOWN" key
11	Back/wake up	"Back/wake up" key
12	Main switch	Main switch
13	"+"	Port Positive *2
14	"-"	Port Negative *2

PRODUCT SPECIFICATION

Model	LF51100-10
Battery Type	LiFePO4
Nominal Voltage	51.2V
Nominal Capacity	100Ah
Charging Cut-off Voltage	51.5V-54V
Discharging Cut-off Voltage	45V-54V
Max. Cont. Charging Current	100A
Max. Cont. Discharging Current	100A
Cycle Life	≥6000
Product Size	530*485*175mm
Weight	47kg
Warranty	5 years



PACKAGING SPECIFICATION

P/N	Power	Packing Size(CM)			PCS/CTN	CBM/CTN	G.W/CTN(KGS)
		L	W	H			
LF51100-10	51.2V 100AH	59.00	54.50	31.50	1	0.1013	57.00

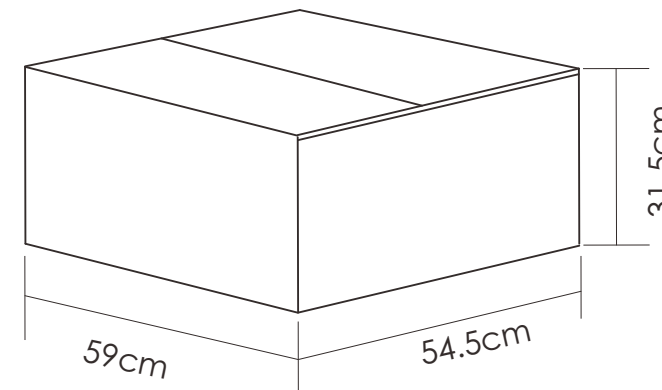

DC Cable Connection

1. Single Unit

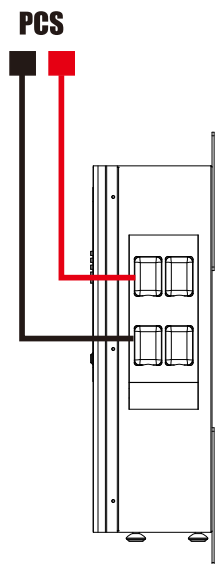

Single Unit Connection

2. Multi-Units in Parallel (4 sets as an example)
Max. Number Of Parallel: 6 Sets

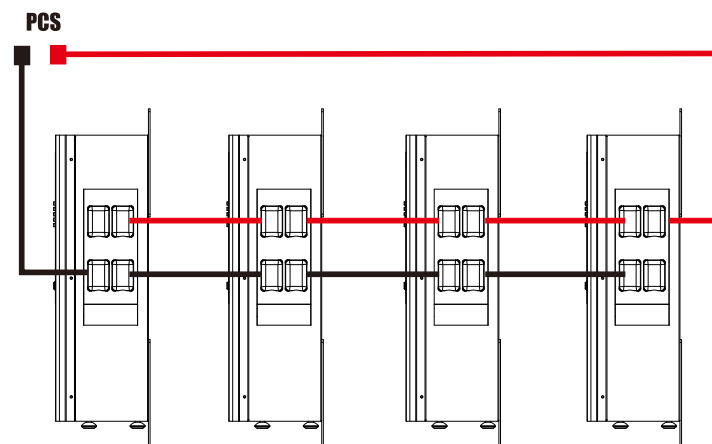

Multi-Units Connection

Master Pack and Slave Pack can be used as single unit as well as multi-units (in parallel) mode. The customer must inform supplier if multi-units mode is required.

ROUTE DIAGRAM

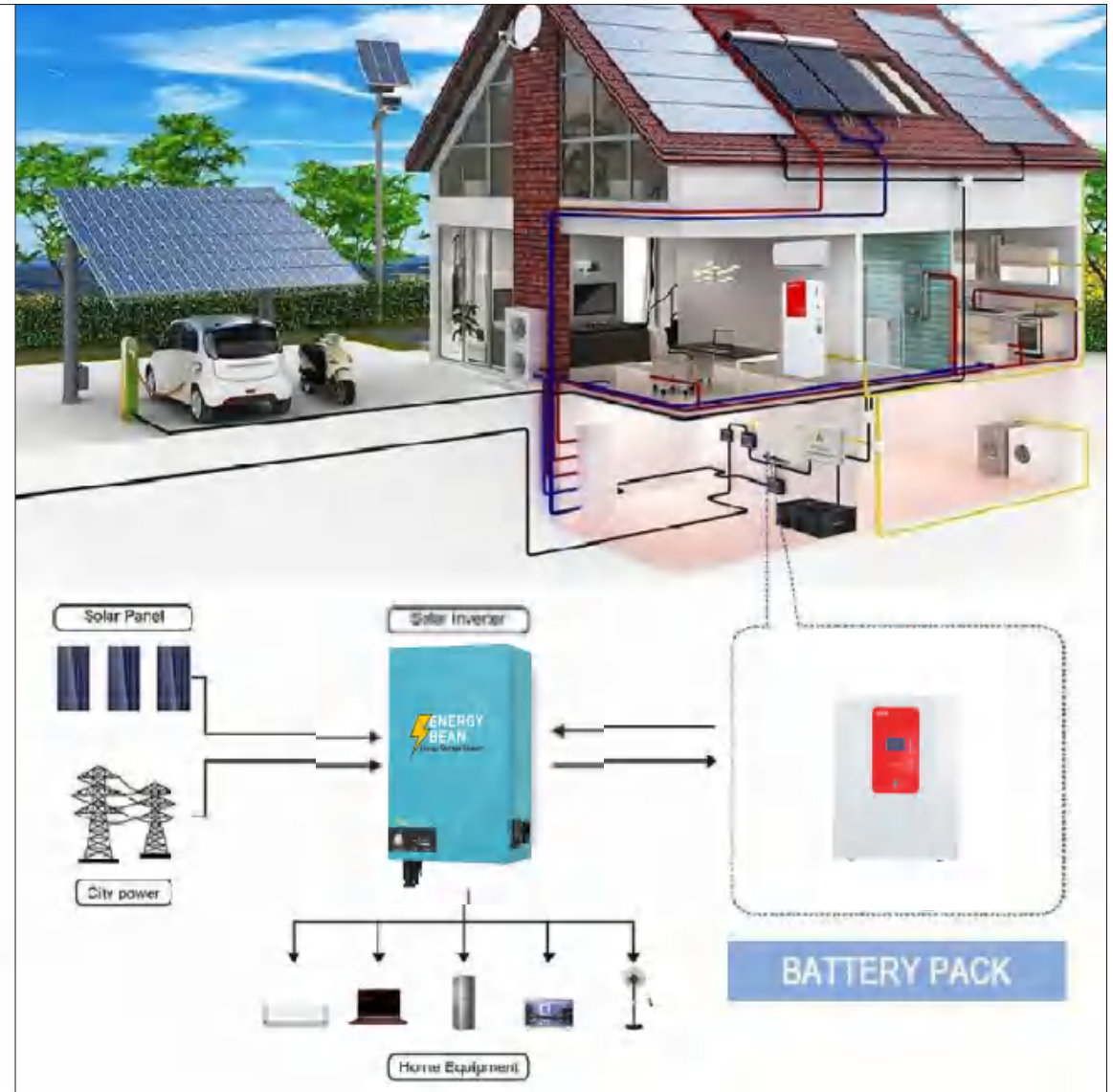
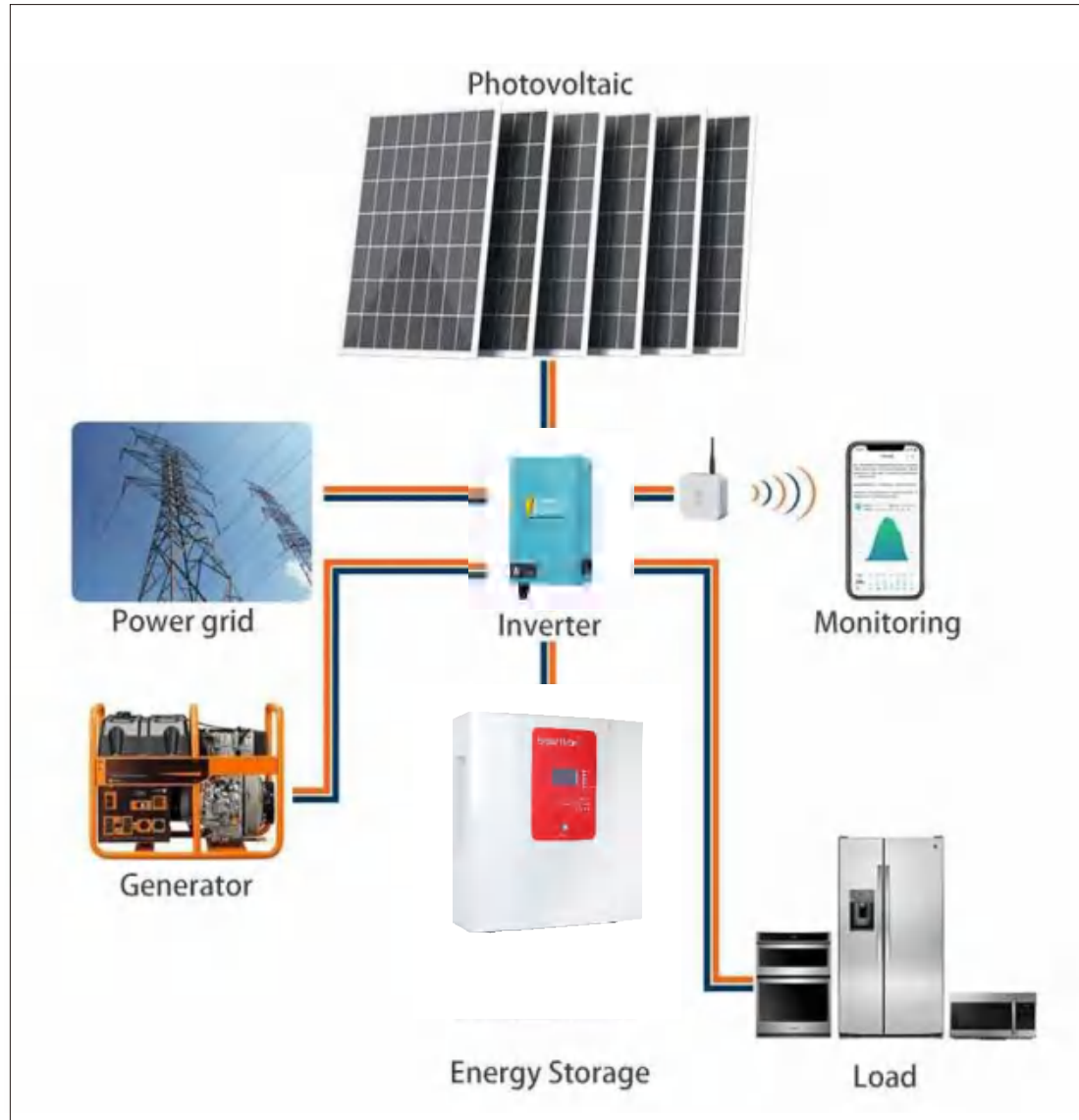

VERSATILE IN ONE BATTERY PACK



BATTERY GUARANTEE OF QUALITY

01

Battery Cells

High-end battery cells keep every cell's voltage, resistance, capacity, discharging always in sync.

02

Battery Protector

High precision IC keep performance more stable protect over load, over charge, over discharge, short circuit, over voltage, over current keep battery pack always safe and long life span.

03

Precision Welding Machine

Fully automatic precision welding machine can ensure that every battery can be welded firmly to prevent the danger of short circuit or power failure.

04

Aging Test Machine

every battery pack need to thorough charging and discharging test by the aging test machine to keep 100% qualified.